

ARMSTRONG

Series SG & Series FTV

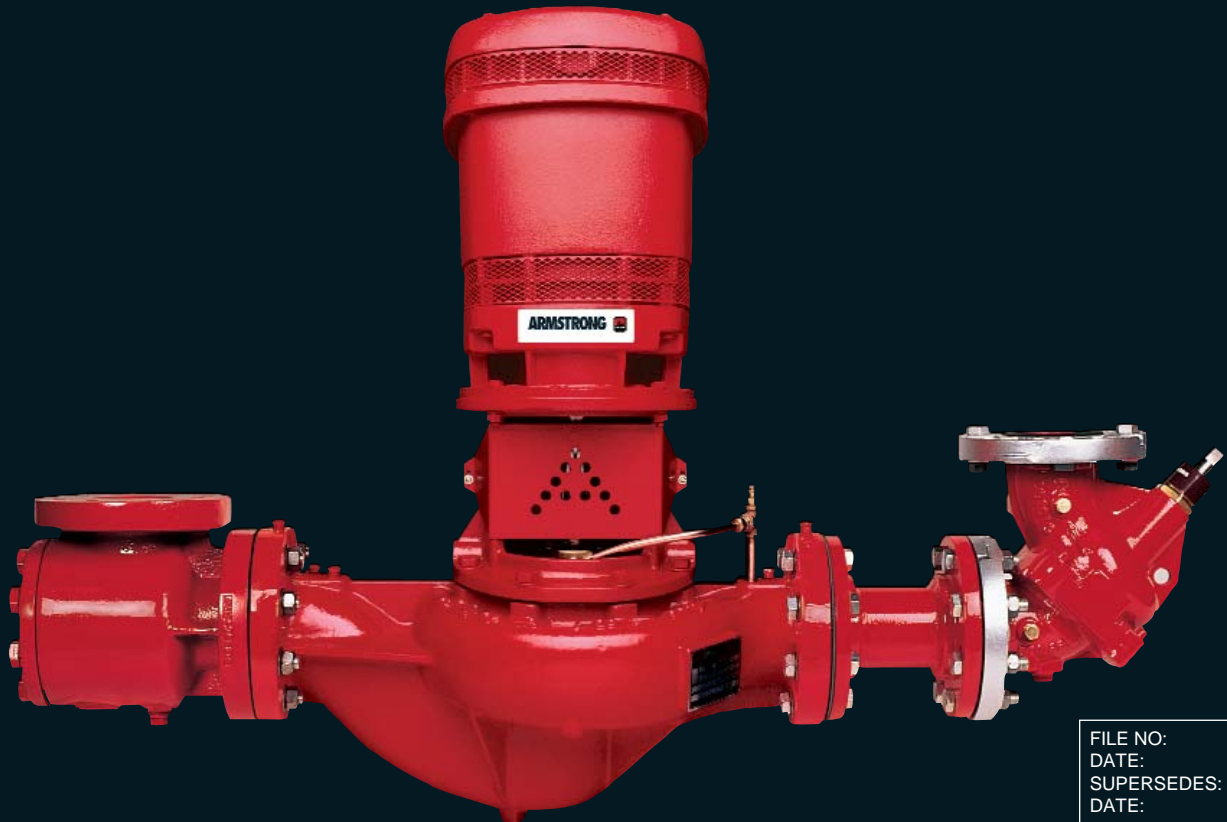

FILE NO:	35.11
DATE:	Oct. 27, 2005
SUPERSEDES:	35.11
DATE:	Jan. 1, 2004

Suction Guides and Flo-Trex Valves

Suction Guides

Designed for direct mounting on the suction flange of horizontal and vertical pumps.



Armstrong Suction Guide Design:

- Model SG: Supplied with cast iron body and 125 psig/PN16 flanges.
- Model SGG: Supplied with ductile iron body with grooved inlet connection and 125 psig/PN16 outlet flange.
- Model SGHH: Supplied with ductile iron body and 250 psig/PN25 flanges.

Model SG, SGG and SGHH Suction Guides

Four-function pump fitting

- **90° Elbow**

Mounting the Suction Guide on any pump suction turns the piping 90°, replacing an elbow. In addition, the Suction Guide can be rotated to any position allowed by the pump suction bolts, from vertical to horizontal.

- **In-Line Strainer**

The stainless steel strainer has free area of at least 250% of pipe sectional area. A disposable fine-mesh strainer is installed for start-up cleaning.

- **Reducing Elbow**

The Suction Guide connects same size piping to the pump suction, but can also connect to inlet piping one size larger than the pump suction, eliminating a reducing elbow.

- **Guide Vanes**

Flow stabilizing vanes on the outlet allow the Suction Guide to bolt directly to the pump, saving the space and cost of a long straight pipe length.

Flo-Trex Valves

Designed for installation on the discharge side of centrifugal pumps.

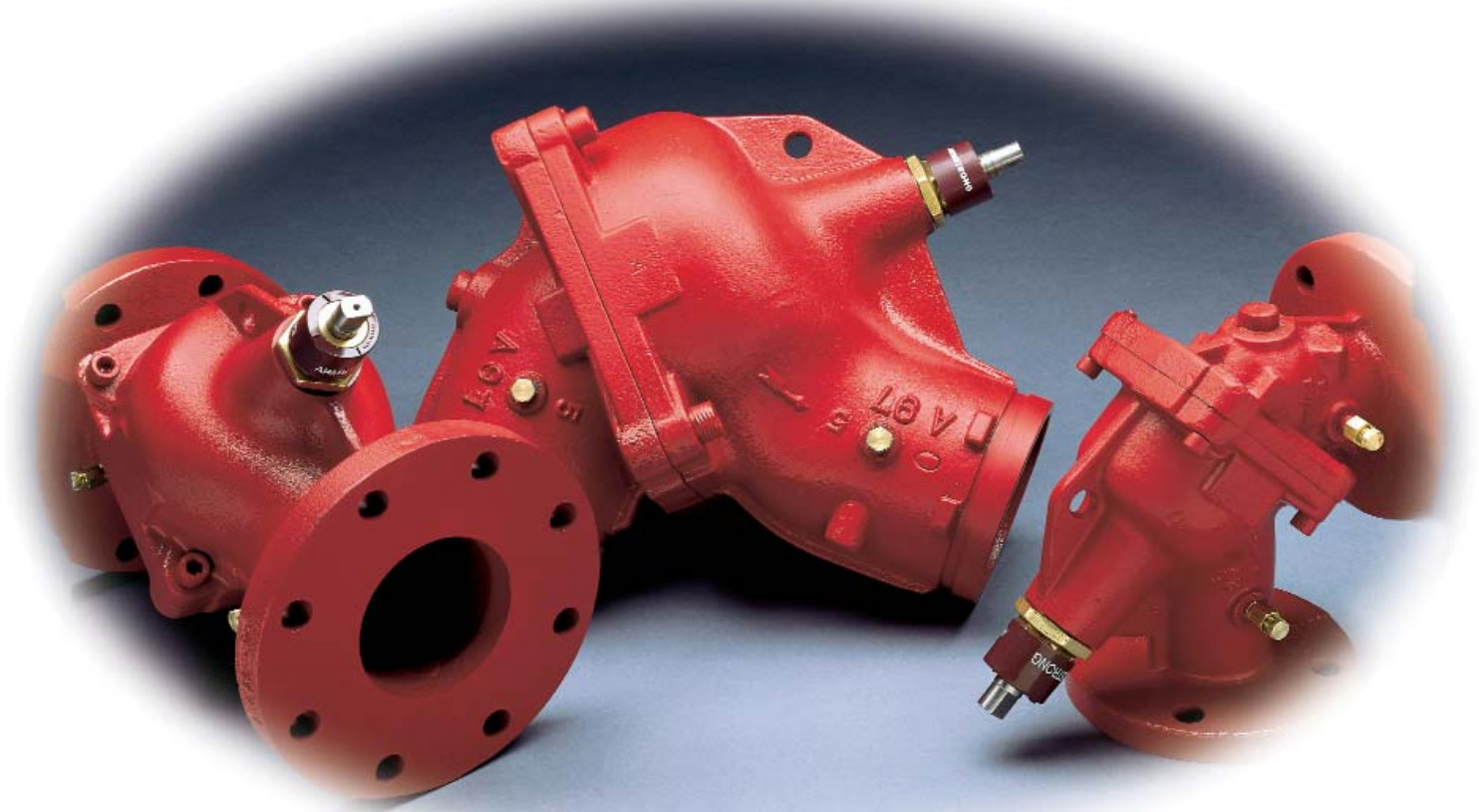

Armstrong Model FTV Flo-Trex Combination Valves

Model FTV-F: Flo-Trex valve is supplied with hard (cast-in) flanges.

Model FTV-G: Flo-Trex valve is supplied with grooved port connections, designed for Armstrong Armgrip™ flange adapters or standard grooved pipe fittings.

Model FTV Flo-Trex Valves

- **Drip-tight Shut Off Valve**

The Armstrong Flo-Trex valve is designed and tested for drip-tight isolation at 150% of maximum working pressure.

- **Non-slam Check Valve**

The Armstrong Flo-Trex valve incorporates a spring closure design that closes the valve in a controlled manner, protecting the valve from slamming due to a reversal in flow caused by gravity or recirculation from a parallel pump.

- **Flow Throttling Valve**

The Armstrong Flo-Trex valve uses a plug and disc design which is the most effective valve type for combining throttling of flow and isolation. Other design valves may be effective for throttling or isolation, but not both.

- **Convertible Body Design**

The Armstrong Flo-Trex convertible body design permits the valve to be changed on-site from straight to angle configuration.

Armstrong Suction Guides and Flo-Trex Valves...

Armstrong Method

- Fewer components required as redundant fittings are eliminated
- Fewer connections required with Armstrong's multi-purpose fittings
- Less installation time required by reducing the number of fittings
- Less installation space required as pump inlet spool piece is eliminated

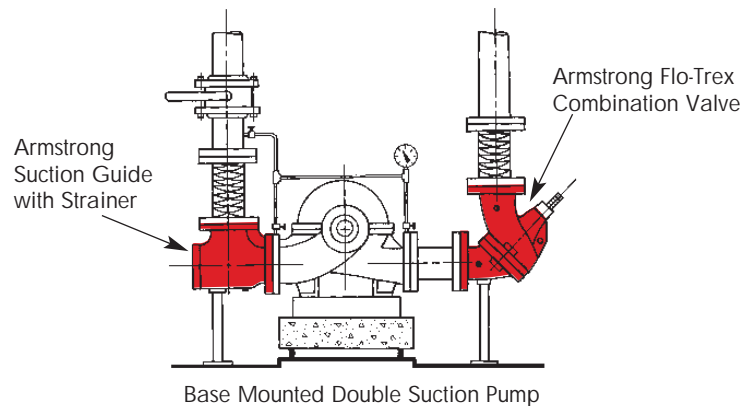
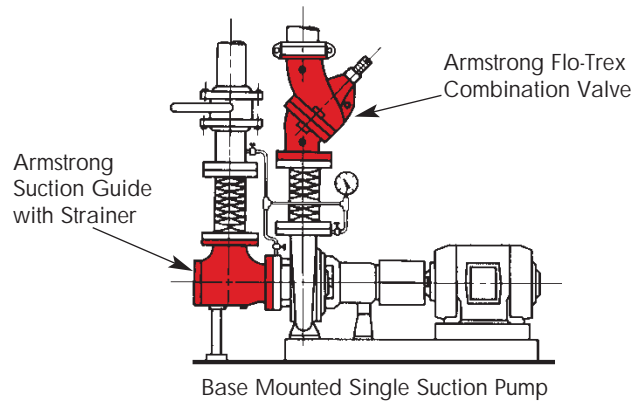

The Smart Choice

An Armstrong Vertical In-Line Pump installation requires the fewest components and connections, maximizing savings and minimizing installation time.

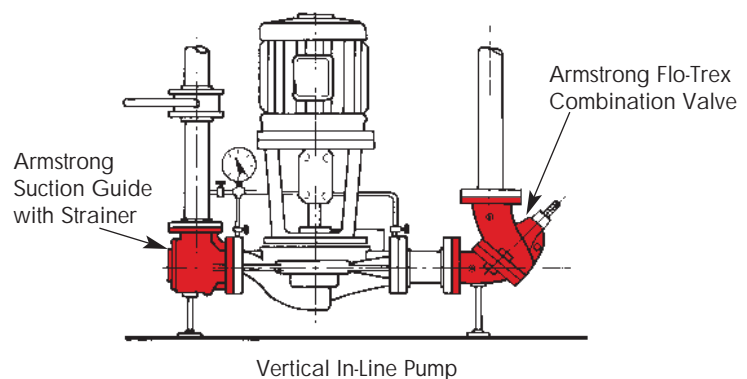

Reduce Field Installation and Materials Costs

Conventional Method

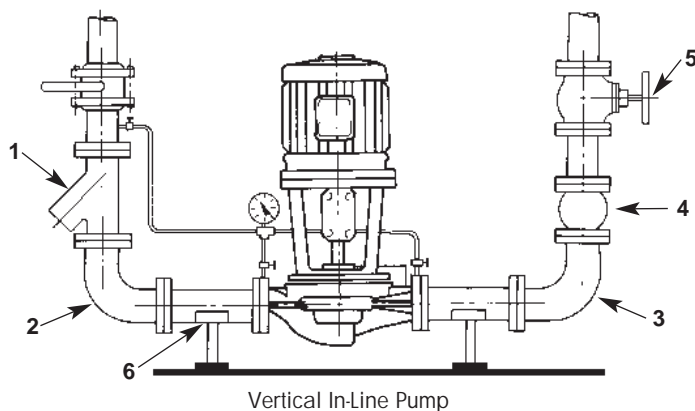
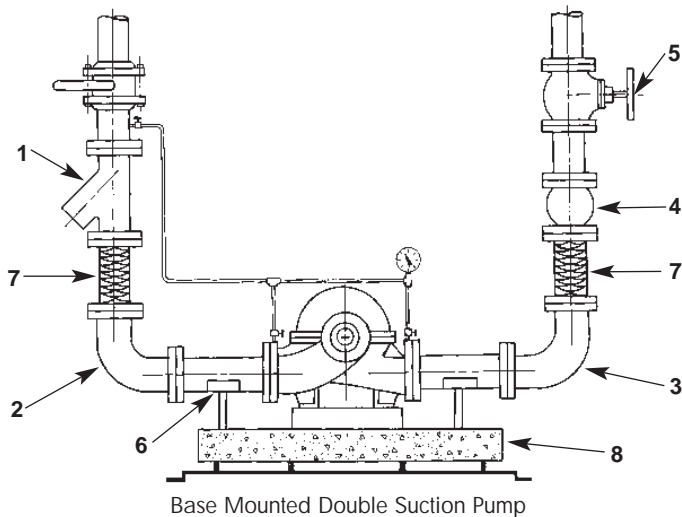
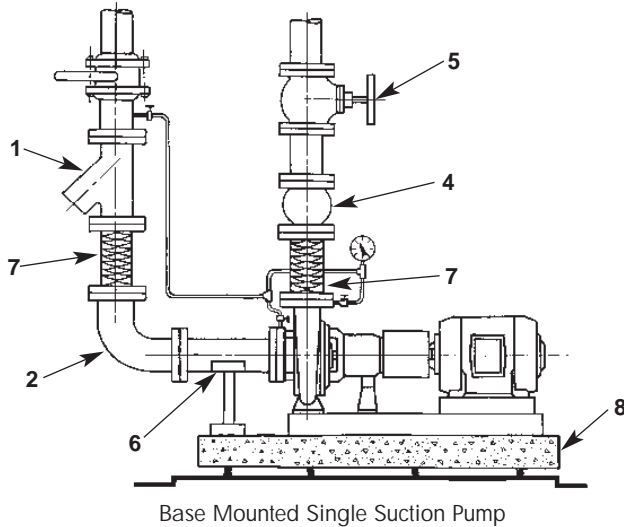

Components eliminated using Armstrong Flo-Trex Valves and Suction Guide strainer for base mounted single and double suction pump installations and Vertical In-Line installations:

1. "Y" Strainer
2. Suction long radius elbow
3. Discharge long radius elbow
4. Discharge check valve
5. Discharge globe valve
6. Suction pool piece

In addition, use of the FTV-G style eliminates three welded flange connections.

Additional components eliminated using Armstrong Vertical In-Line pumps with Flo-Trex Valves and Suction Guide strainers in place of base mounted applications:

7. Flexible connectors
8. Inertia base isolation
9. Field shaft alignment (not shown)

Materials of Construction

Suction Guides

Model	Body	Cover	Strainer 1/8" (3 mm) Perforations	Fine-Mesh (Start-Up) Strainer	Guide Vaness
SG	Cast Iron	Ductile Iron	Stainless Steel	Galvanized Steel	Cast Iron
SGG, SGHH	Ductile Iron	Ductile Iron	Stainless Steel	Galvanized Steel	Ductile Iron

Flo-Trex Valves

Model	Body	Disc	Stem & Spring	Seat & O-Ring	Port Fittings
FTV-F 125#/PN16	Cast Iron	Bronze	Stainless Steel	EPDM	Brass
FTV-F 250#/PN25	Ductile Iron	Bronze	Stainless Steel	EPDM	Brass
FTV-G	Ductile Iron	Bronze	Stainless Steel	EPDM	Brass

Suction Guide Body

Cast iron, or ductile iron, with ANSI or PN16 flanges. Same size ports are available with oversized inlet flange to eliminate reducer.

Guide Vanes

Stabilizing vanes reduce turbulence, thereby creating optimum flow conditions and minimizing stress on pump components.

Strainer

1/8" (3 mm) perforated stainless steel, star-shaped for added strength, designed to provide large free flow area to reduce pressure drop.



Armstrong Model SG Suction Guide

Start-up strainer

Removable fine mesh strainer, furnished as a standard item, helps prevent mechanical seal or instrument damage during initial run period.

Optional magnet to help eliminate free floating metallic particles from system.

Removable cover, with O-ring, enables easy access to strainer.

Maximum Operating Parameters

Suction Guide & Flo-Trex Pressure/Temperature Parameters

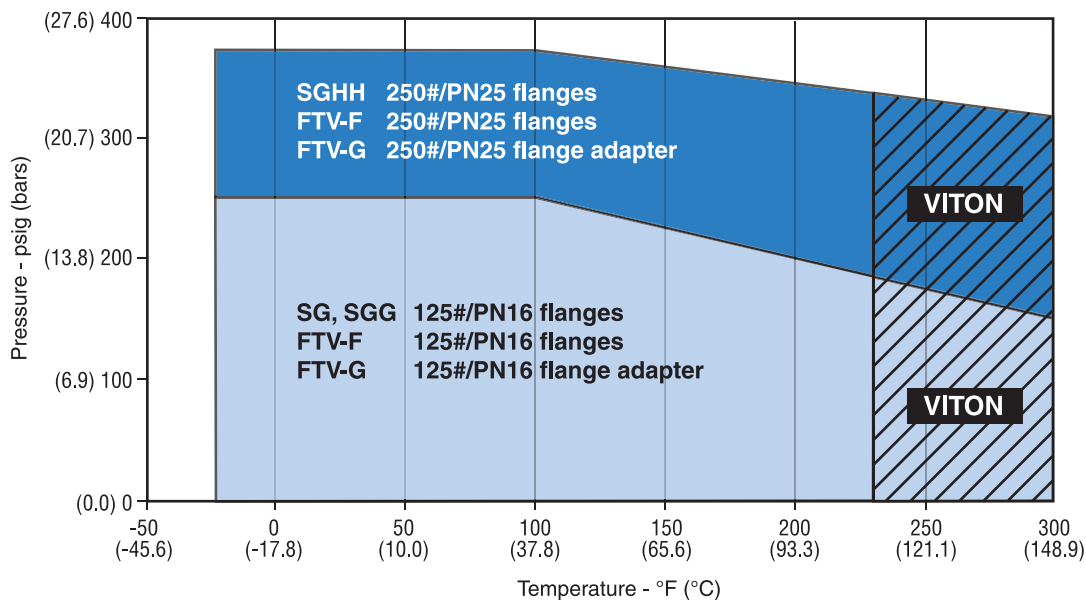

Note: For temperatures from 230°F to 300°F (110°C to 149°C) use Viton Elastomer.

Technical Information

Design Benefits

- Reduced field installation and material costs
- Cast iron or ductile valve body with hard flanges, or ductile iron valve body with standard grooved ends
- Eliminates requirement for two separate valves on pump discharge and, in some cases, a 90° elbow
- FTV-G eliminates three welded flange connections
- Soft seat to ensure tight shut-off
- Spring-closure design uses a non-slam silent check valve feature for vertical mounting
- Flow measurement and pump throttling capabilities
- Temperature measurement capability
- Spring-closure design check valve prevents gravity or reverse circulation when pump is not operating
- Bonnet "O" Ring can be replaced under full system pressure by back seating of valve stem
- Suitable for maximum working pressure up to 375 psi (26 bars) and temperatures up to 230°F (110°C)
- Optional Viton elastomer for temperatures up to 300°F (150°C)
- Valve seat can be changed in the field without use of special tools
- Low pressure drop due to "Y" pattern valve design
- Valve C_v designed to ASHRAE flow recommendations for quiet system operation

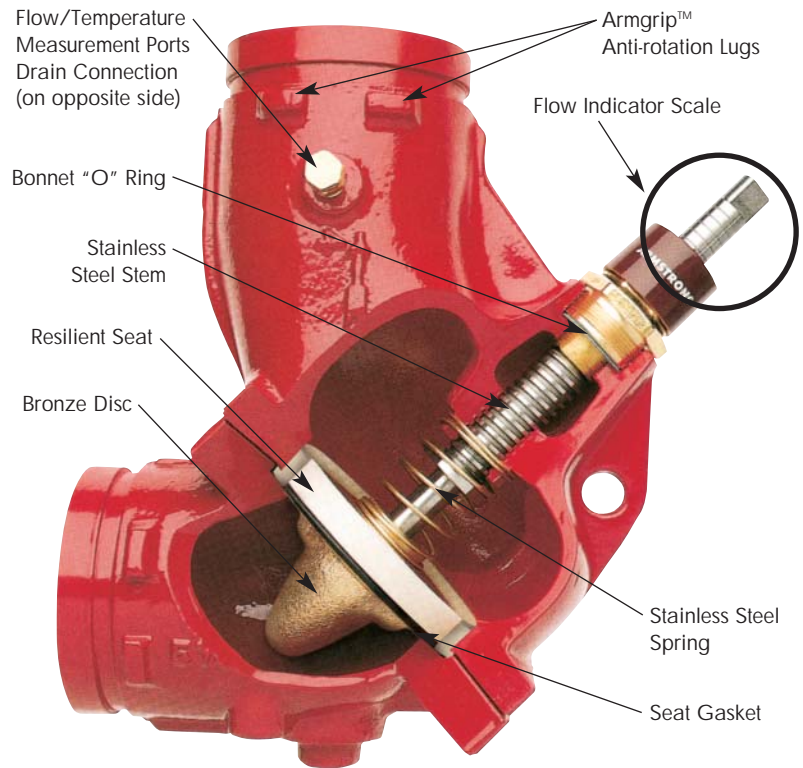

Armstrong Model FTV-GA Flo-Trex Valve

Flow Indicator Scale

The valve stem, with its grooved rings and positioning sleeve, indicates the throttle position of the valve. The quarter turn graduations on the sleeve, with the scribed line on the stem, provide for approximate flow measurement.



Flow Indicator Scale



Armstrong Armgrip™ Flange Adapter



Gasket

Hard Flanged Body or Armgrip™ Flange Adapter

The hard flanged body or the combination of the Armstrong flange adapter and Flo-Trex body, equipped with the unique Armgrip™ anti-rotation lugs, ensures a rigid pump installation.

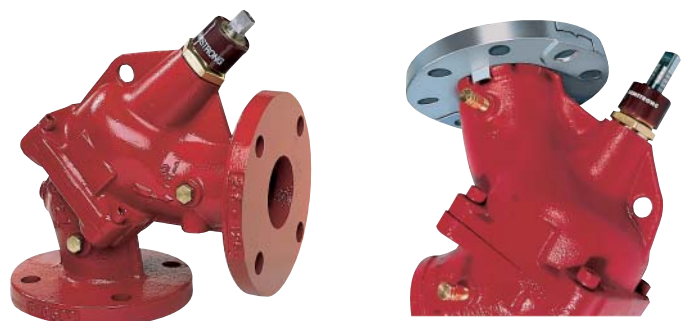

Typical Specification - Pump Trim

Suction Guides

Furnish and install on the suction of each pump an Armstrong Suction Guide, with Outlet Flow Stabilizing Guide Vanes, removable Stainless Steel Strainer and Fine Mesh Start-up Strainer.

For 150 psig/PN16 flanged pipe - Supply valve with Cast Iron body with 125 psig/PN16 flanged ports.

For 150 psig grooved systems - Supply valve with Ductile Iron body with grooved inlet connection and 125 psig/PN16 outlet flange.

For 300 psig/PN25 flanged pipe - Supply valves with Ductile Iron body and 250 psig/PN25 flanged ports.

The mechanical contractor shall inspect the strainer prior to activating the pump and, further, shall remove the Fine Mesh Start-up Strainer after a short running period (24 hours maximum). Space shall be provided for removal of the Strainer and connection of a blow-down valve.

Flo-Trex Valves

Furnish and install on the discharge side of each pump an Armstrong Model FTV Flo-Trex Combination Valve. Each valve is to incorporate the following three functions in one body: Tight shut-off, spring-closure type silent non-slam check and effective throttling with flow measurement capability. The body shall have (2) 1/4" NPT connections on each side of the valve seat. Two connections to have brass pressure and temperature metering ports, with Nordel check valves and gasketed caps. Two other connections to be supplied with brass drain plugs. Metering ports are to be interchangeable with drain ports to allow for measurement flexibility when installed in tight locations. The valve disc shall be bronze plug & disc type with high impact engineered resin seat to ensure tight shut-off and silent check operation.

The valve stem shall be stainless steel with flat surfaces provided for adjustment with open-end wrench.

For Grooved Piping: Valve body shall be ductile iron with grooved ends and Armstrong anti-rotation Armgrip™ lugs on the inlet and outlet of the body.

Flange adapters, where necessary, are to be Armstrong Armgrip™ 125 psig/PN16 or 250 psig/PN25 ductile iron flanges with anti-rotation lugs and EPT gaskets.

For Welded Flange Piping:

For 150 psig/PN16 flanges - Valve body shall be Cast Iron with 125 psig/PN16 flanged ports.

For 300 psig/PN25 flanges - Valve body shall be Ductile Iron with 250 psig/PN25 flanged ports.

The valve shall be selected and installed in accordance with the manufacturer's instructions and be suitable for the pressure and temperature specified.

Insulation (Available for 2.5" - 6"/65-150 Flo-Trex Valves)

Each valve shall be furnished with a pre-formed removable PVC insulation jacket to meet ASTM D1784 Class 14253-C, MEA #7-87, ASTM-E-84 and ASTM136 with a flame spread rating of 25 or less and a smoke development rating of 50 or less. There will be provided sufficient mineral fiberglass insulation to meet ASHRAE 90.1-1989 specifications in operating conditions with maximum Fluid Design Operating Temperature Range of 141°F-200°F (60°C-93°C) and Mean Rating Temperature of 125°F (52°C).

Armstrong Pumps Inc.
93 East Avenue
North Tonawanda, New York
U.S.A. 14120-6594
Tel: (716) 693-8813
Fax: (716) 693-8970

Armstrong Holden Brooke Pullen
Wenlock Way
Manchester
United Kingdom, M12 5JL
Tel: +44 (0) 1612 232223
Fax: +44 (0) 1612 209660



S.A. Armstrong Limited
23 Bertrand Avenue
Toronto, Ontario
Canada, M1L 2P3
Tel: (416) 755-2291
Fax: (416) 759-9101

Armstrong Darling
9001 De L'Innovation, Suite 200
Montreal (Anjou), Quebec
Canada, H1J 2X9
Tel: (514) 352-2424
Fax: (514) 352-2425

