

Installation and Operating Instructions and Parts List

Armstrong Model FTV Hard Flanged Flo-Trex Combination Valve

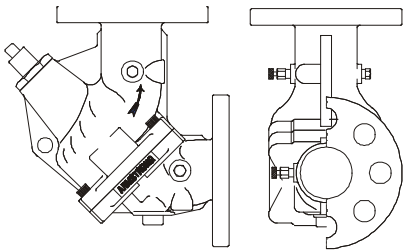

Angle Pattern Model FTV-AF

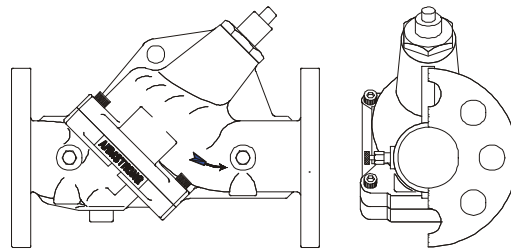

Straight Pattern Model FTV-SF

Table of Contents

Item	Description	Page
1.0	Introduction	2
2.0	Installation	2
3.0	Flange Bolt Tightening	3
4.0	Pressure Temperature Limits	3
5.0	Field Conversion	3
6.0	Flow Measurement	3, 4
7.0	Operation	5
8.0	Repacking Valve	5
9.0	Maximum Number of Turns	5
10.0	Seat Replacement	5
11.0	Parts List	6

1.0 INTRODUCTION

1.1 The Armstrong Model FTV Flo-Trex Combination Valves are designed for installation on the discharge side of centrifugal pumps. The Armstrong Combination Valve incorporates three functions in one valve:

- Drip-tight, shut-off valve ·
- Spring closure design. Non-slam check valve ·
- Flow throttling valve

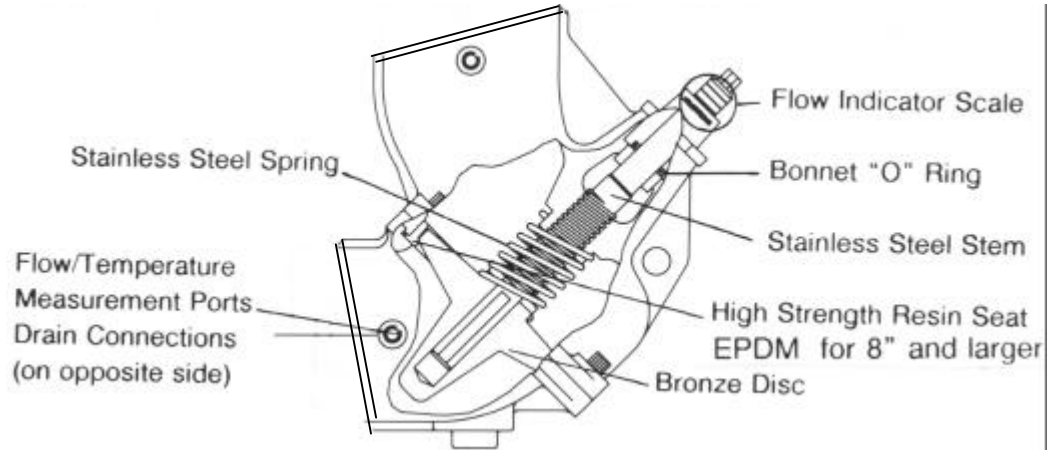

**Armstrong Model FTV-AF
Flo-Trex Combination Valve**

2.0 INSTALLATION

- 2.1 The valve should be mounted to a spool piece on the discharge side of the pump. Spool piece required is based on a minimum recommended space of 12" for pump sizes 2 x 2 to 6 x 6 and 24" for pump sizes 8 x 8 to 12 X 12.
- 2.2 It is not recommended to mount a valve directly to the pump as this could cause undesirable noise in the system.
- 2.2 Sufficient clearance around the valve should be left for valve removal or repair.
- 2.3 Install valve in the direction of the flow arrows on the valve body.
- 2.5 The valve body has been designed to handle the weight of the pump on vertical in-line installations. The body is not designed to support the piping weight. It is recommended that the piping be supported by hangers. Pipe supports should be provided under the valve and strainer bodies.

Typical Installations

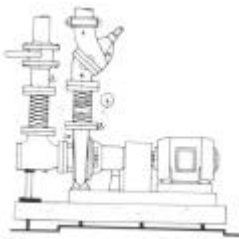

Base-Mounted Single Suction

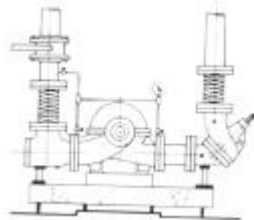

Base-Mounted Double Suction

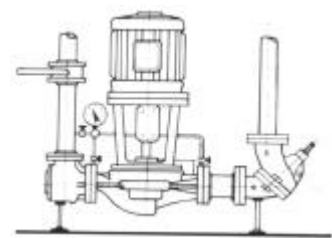

Vertical In-Line

For additional information on Armstrong Model SG Suction Guides, request File 35.10.

3.0 FLANGE BOLT TIGHTENING

Recommended Bolt Tightening Procedure

Valve Size	125 psi/150 psi Cast Iron	
	Bolt	
	No.	Size
2-1/2	4	5/8
3	4	5/8
4	8	5/8
5	8	3/4
6	8	3/4

Table 1

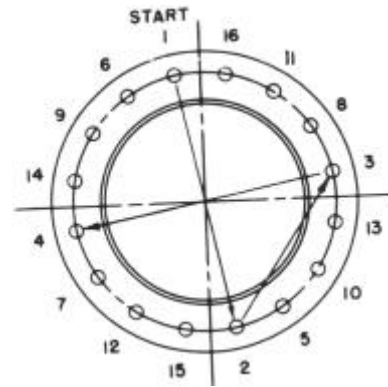
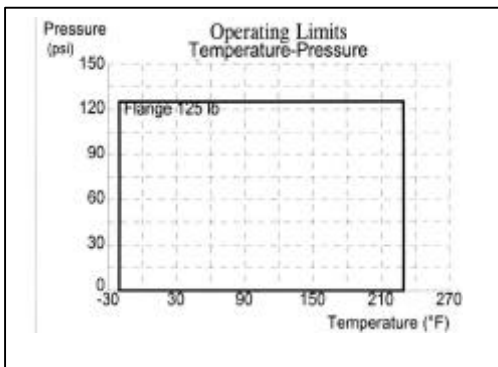

Fig. 1

3.1 Tighten nuts evenly, following bolting instructions (fig.1) so that the flange faces remain parallel. Flange bolts should be tightened to 70 ft/lbs. Torque minimum to assure firm metal-to-metal contact. When raised face flanges are used, there will be a gap between the faces of the outer diameter.

4.0 PRESSURE TEMPERATURE LIMITS



5.0 FIELD CONVERSION (Straight to Angle pattern valve)

- 5.1 Open valve at least one complete turn.
- 5.2 Remove the body bolts from valve body using Allen Key.
- 5.3 Rotate one half of the valve body 180° making sure the lower valve seat and "O" Ring stay in position. Inspect the "O" Ring for any cuts or nicks and replace if necessary.
- 5.4 Replace body bolts and torque evenly to 70 ft/lbs.

6.0 FLOW MEASUREMENT

6.1 Where approximate indication of flow is acceptable the Armstrong Flo-Trex valve can be used.

6.2 FLOW MEASUREMENT VALVE IN WIDE OPEN POSITION

6.2.2 Measure and record the differential pressure across the valve using an Armstrong CompuFlo with high pressure range transducer, or CBDM- 135/60 meter, or pressure gauges with PMP adapters.
Caution: Safety glasses should be used and the probe should not be left inserted into fittings for prolonged periods of time (overnight, etc), as leakage from the PMP may occur when probe is removed.

6.23 Refer to Flo-Trex Performance Curves with valve in full open position (Fig 2).

Locate Pressure Differential on left hand side of chart and extend line horizontally across to valve size being used. Drop line vertically down and read flow rate from bottom of chart.

6.3 DETERMINING FLOW RATE WITH VALVE IN THROTTLED POSITION

Flo-Trex Performance Curve with Valve in Full Position

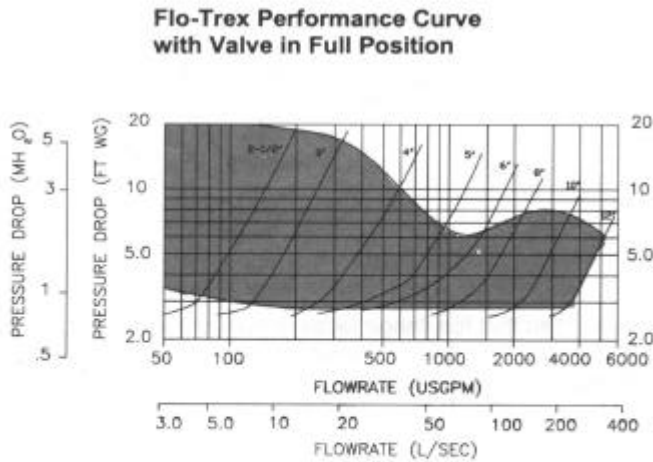

Fig. 2

Inherent Flow Characteristic Curve with Valve in Throttled Position

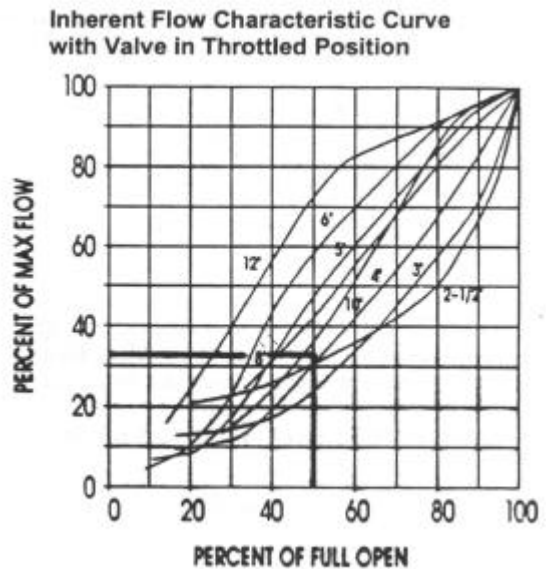

Fig. 3

6.31 Record the size of the valve and stem position using the Flow Indicator Scale (page 5). Calculate percentage of valve opening referring to table below:

Valve Size	2 1/2	3	4	5	6	8	10	12
Number of Rings (valve full open)	5	5	6	9	10	12	18	28

6.3.2 Measure and record the differential pressure across the valve in the throttled position.

6.3.3 Locate percentage of valve opening on the bottom scale of Flow Characteristic Curve (fig 3). Project line vertically up to intersect with the Valve Characteristic Curve and from this point project line horizontally across to the left of the chart and record the percentage of maximum flow rate.

6.3.4 On the Flo-Trex Performance Curve (fig. 2) locate the differential pressure obtained in Step 6.3.2 and project line horizontally across to intercept with Valve Performance Curve. Drop a line vertically down to read the flow rate at the bottom of the chart.

6.3.5 To calculate flow rate of valve in the throttled position, multiply the flow rate from Step 6.3.4 by the percentage flow rate from Step 6.3.2 divided by 100.

Example: Valve size 4 inch.

Differential Pressure is 5.4 ft. (1.65 m).

Number of rings open = 3. Therefore: 3 rings ÷ 6 rings x 100 = 50% throttled.

- From the Flo-Trex Performance Curve (fig 2), a 4 inch, valve with 5.4 ft. pressure drop (1.65 m) represents a flow of 400 USgpm (25.2 l/s).

- From Flow Characteristic Curve (fig 3), a 4 inch valve 50% open, represents 34% of maximum flow. Approximate flow of a 4 inch valve, with a 5.4 ft. (1.65 m) pressure drop when 50% throttled is:

$$\frac{400 \times 34}{100} = 136 \text{USgpm} \text{ or in metric } \frac{25.2 \times 34}{100} = 8.57 \text{l/s}$$

Note: To prevent premature valve failure it is not recommended that the valve operate in the throttled position with more than 25 ft. pressure differential. Instead the pump impeller should be trimmed or valves located elsewhere in the system be used to partially throttle the flow.

Flow Indicator Scale

The valve stem with its grooved rings and positioning sleeve indicates the throttled position of the valve. The quarter turn graduations on the sleeve, with the scribed line on the stem provides for approximate flow measurement.

Note: The valve is shipped in the closed position. The indicator on the plastic sleeve is aligned with the vertical scribed line on the stem.



7.0 OPERATION

- 7.1 To assure tight shut off the valve must be closed using a wrench with 25 to 30 ft/lbs. of torque.
- 7.2 To assure trouble-free check valve operation and shut off operation, the valve should be periodically opened and closed to keep valve seat and valve disc guide stem free of build up of system contaminants.

8.0 REPACKING OF FTV UNDER FULL SYSTEM PRESSURE

- 8.1 Should it be necessary, stem "O" Ring can be changed under full system pressure.
Caution: Safety glasses should be worn.
- 8.2 Record the valve setting.
- 8.3 Turn the valve stem counter-clockwise until the valve is fully open and will not turn any further. Torque to a maximum force of 45 ft/lbs. This will ensure good metal-to-metal contact and minimum leakage.
- 8.4 The valve bonnet may now be removed. There may be a slight leakage. As the metal-to-metal back seating does not provide a drip-tight seal.
- 8.5 Clean exposed portion of valve stem (Do not scratch).
- 8.6 Remove and replace the 'O' Ring and gasket.
- 8.7 Install the valve bonnet.
- 8.8 Tightening valve bonnet is necessary to stop any leaks.
- 8.9 Open valve to balance set point as recorded in 8.2.

9.0 MAXIMUM NUMBER OF TURNS FULL OPEN VALVE

Note: On valve sizes 2-1/2" and 3", full open position of valve is 5 turns. However valve will open to 5-1/2 turns which is just back of seating of valve.

10.0 SEAT REPLACEMENT

- 10.1 Drain system and remove valve from piping.
- 10.2 Remove the body bolts from the body using an Allen Key.
- 10.3 Remove seat and "O" Ring.
- 10.4 Inspect and clean 'O' Ring cavity and install new "O" Ring and seat. Valve disc stem also should be inspected and replaced if worn. Valve stem 'O' Ring should be replaced at this time. Refer to section 8.

Flo-Trex Valves Replacement Parts List

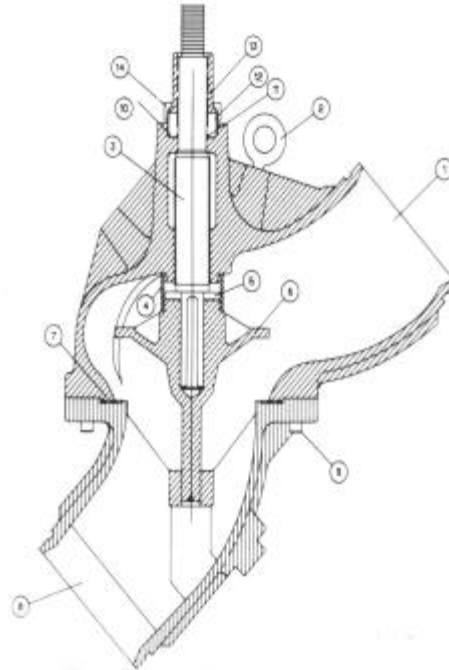

11.0 Parts List

Part	Item No.	2-1/2" Straight or Angle	3" Straight or Angle	4" Straight or Angle	5" Straight or Angle	6" Straight or Angle
Shaft	3	570202-006	570202-006	570202-006	570202-007	570202-007
Spring	4	570203-002	570203-003	570203-004	570203-005	570203-006
Bushing	-	570223-001	570223-001	570223-002	570223-001	570223-002
Bonnet	13	570201-006	570201-006	570201-006	570201-006	570201-006
Eye Bolt	2	N/A	N/A	N/A	N/A	N/A
Cap-Sleeve	15	N/A	N/A	N/A	N/A	N/A
"O" Ring **	12	961131-210	961131-210	961131-210	961131-210	961131-210
Sleeve	14	570216-000	570216-000	570216-000	570216-000	570216-000
Spacer	5	570198-006	570198-006	570198-006	570198-006	570198-006
Disc	6	570232-041	570233-041	570234-041	570235-041	570236-041
Body Main	1	570518-611	570520-611	570522--611	570524-611	570526-611
Seat **	7	570196-000	570196-001	570196-002	570196-003	570196-004
"O" Ring Body **	8	961131-238	961131-242	961131-250	961131-259	961131-263
Body Suction	9	570500--611	570502-611	570504-611	570506-611	570508-611
Capscrew	10	911821-112	911821-112	911825-112	911829-114	911829-114
Performed Insulation (Straight)	-	570225-386	570225-387	570225-388	570225-389	570225-390
Performed Insulation (Angle)	-	570225-486	570225-487	570225-488	570225-498	570225-490

** Recommended Spare Parts

Common parts to all: Gasket - 570217-006; 14" Brass Pipe Plug - 935105-001; 14" Brass Metering Ports - 570148-001

S.A. Armstrong Limited
23 Bertrand Avenue
Toronto, Ontario
Canada, M1L 2P3
Tel: (416) 755-2291
Fax: (416) 759-9101

Visit us at armstrongpumps.com

Armstrong Pumps Limited
Peartree Road, Stanway
Colchester, Essex
United Kingdom, C03 5JX
Tel: 01206-579491
Fax: 01206-760532



© S.A. Armstrong Limited 1998

Armstrong Pumps Inc.
93 East Avenue
Buffalo, New York
U.S.A. 14120-6594
Tel: (716) 693-8813
Fax: (716) 693-8970

Armstrong Darling Inc.
2200 Place Transcanadienne
Montreal, Quebec
Canada, H9P 2X5
Tel: (514) 421-2424
Fax: (514) 421-2436

