

INSTALLATION AND OPERATING INSTRUCTIONS

ARMflo E Series High Efficiency Circulator

READ CAREFULLY BEFORE INSTALLING & OPERATING THE CIRCULATOR

INSTALLER: PLEASE LEAVE THIS MANUAL FOR THE OWNER'S USE

You are about to install an ARMflo E Series circulator - a high-efficiency pump from Armstrong. ARMflo E Series circulators are designed for heating and cooling in hydronic, geothermal or solar systems, circulating water or ethylene glycol/water solutions. For pumping domestic (potable) water, Armstrong recommends the use of circulators with bronze body construction.

The ARMflo E Series circulators are extremely efficient and quiet and utilize a state of the art permanently lubricated bearing system designed for many years of trouble-free operation. They feature a permanent-split capacitor motor with thermal protection.

OPERATING LIMITS

- Maximum operating pressure: 150 psi (1034 kPa)
- Maximum operating temperature: All Standard Models – 230°F (110°C)
Models Ending in -TE – 150°F (65°C)
- Electrical Rating: 120 V, 1 Phase, 60 Hz (240 V, 1 Phase, 60 Hz available for some models)

When unpacking the circulator, inspect for any damage that may have occurred during transit. Check for loose, missing or damaged parts.

THIS PUMP IS FOR INDOOR USE ONLY

INSTALLATION

Before installing the circulator, proper installation practice recommends a thorough flush of the hydronic system, ensuring removal of all foreign materials prior to installing the circulator.

Check that the flow direction of the water through the hydronic system matches the arrow on the circulator body. The circulator is supplied for installation with an up discharge direction.

The ARMflo E Series circulators can be installed to discharge up or down, horizontally left or right, but the circulator shaft must remain in the horizontal position. It is recommended that the circulator be installed such that the terminal box is installed on the top or side of the motor housing but NOT underneath the motor housing. The piping can be in a horizontal or vertical run. Isolation valves should be installed on the discharge and suction side of the pump to facilitate service.

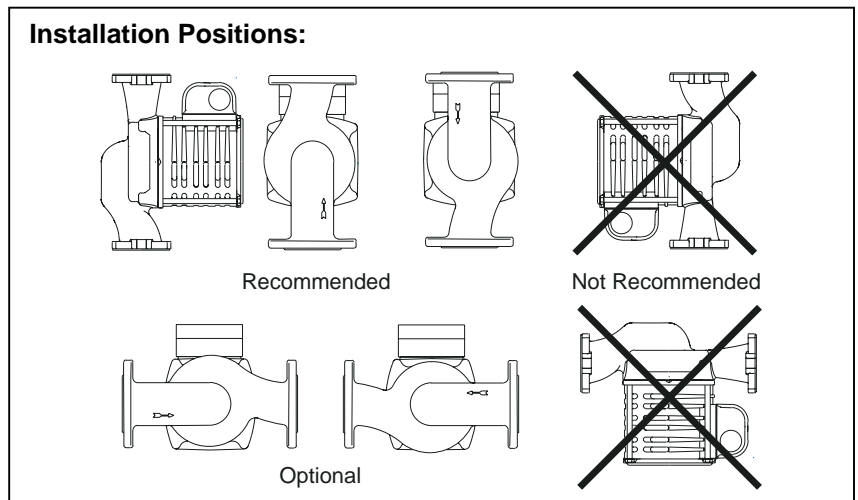



Terminal Box

If the terminal box is found to be positioned inconveniently, it can be rotated as required through 90° increments. See Examples shown in “Installation Positions”.

Electrical Wiring

The electrical wiring must be installed in strict accordance with the Canadian Electrical Code or the US National Electrical Code, as well as local codes and regulations.

- A. Electrical installation should be conducted by a qualified electrician.
- B. The motors of ARMflo E Series circulators are designed for 60 Hz, 1 Phase, 120 V or 240 V service only. (Please refer to the rating label on the circulator’s terminal box to determine the correct voltage.)
- C. Always make sure the electric power is disconnected and locked out before wiring the circulator.
- D. To wire, loosen the screw from the terminal box cover and remove the screw and cover.
- E. Install the appropriate size conduit end to one of the holes on either side of the terminal box.
- F. Connect the hot (black) and neutral (white) leads of the supply wire to the black and white leads respectively inside the terminal box. Connect the ground wire to any one of the three green ground screws inside of the terminal box (use a minimum 18 awg wire size).
- G. Replace the terminal box cover.

The motor is thermally protected for your safety so overload protection is not necessary. All that is required is a fused plug or circuit breaker in the power line.

Electrical information can be found on the nameplate of the motor.

START UP

- A. Before starting up the circulator, proper installation practice recommends a thorough flush and draining of the hydronic system, ensuring removal of all foreign materials. Fill the system with clean water or glycol solution before starting.
- B. Air must be completely vented from the system before starting up the circulator. **If the system is not completely vented of air and the circulator is allowed to run dry, the mechanical seal will be damaged.**
- C. When the system has been completely filled and vented, only then can the pump be started.

ARMflo E Series circulators are fitted with permanently lubricated ball bearings and DO NOT require lubrication.

Disconnect and lockout the power before servicing.

REPLACEMENT OF PUMP FROM EXISTING INSTALLATION

1. If valves have been installed on the suction and discharge sides of the pump, close them before attempting to remove the circulator from the system. If no valves have been installed, it may be necessary to drain the system.
2. For safety, allow water to cool to 100°F (40°C) before draining the system. It is best to leave the drain valve open while working on the system.
3. Ensure that electric power is disconnected and locked out before disconnecting the wiring to the circulator. Then, loosen the screw from the terminal box cover and remove the screw and cover. Disconnect the supply wires only to the circulator, leaving the capacitor wires connected.
4. To relieve any residual pressure which may be present in the pump body, loosen the flange bolts and gently move the pump body back and forth a bit to allow the pressurized water to escape.
5. Remove the flange bolts and nuts and then remove the circulator from the piping.
6. Install the ARMflo E Series circulator where there will be sufficient room for inspection and service. It is recommended that isolation valves be installed on both the suction and discharge sides of the circulator for future servicing (this eliminates the need for draining the system when working on the circulator, for example when replacing the mechanical seal).
7. Install suction and discharge flanges on the pipe ends. The use of Teflon tape sealer or a high quality thread sealant is recommended.
8. Pipe strain can be minimized by the use of pipe hangers near the pump, positioned to support the suction and discharge piping.

To wire the ARMflo E Series circulator, follow steps C through G in the “Electrical Wiring” section above, noting that electrical supply and grounding wires must be rated for at least 194°F (90°C).

PREVENTIVE MAINTENANCE - INSPECTION

Although Armstrong long-life circulators are designed to provide years of worry-free service, it is good maintenance practice to inspect the entire hydronic system periodically - including the ARMflo E Series Circulator - for potential problems. If there is any evidence of leakage or damage, repair or replace the pump.

INSTRUCTIONS FOR REPLACING MECHANICAL SEAL

[Start by following steps 1 and 2 of section titled "REPLACEMENT OF A PUMP FROM AN EXISTING INSTALLATION".]

1. Turn off the pump leaving it installed in the line.
2. Ensure electrical power is disconnected and locked out.
3. Close the water supply at the points closest to the pump's inlet and outlet.
4. Bleed the water pressure from the pump.
5. Place a pan under the pump to collect the drain water.
6. While holding the motor body, unfasten the four bolts that attach the motor to the pump casing (volute). Start with the two bottom bolts first and remove them, then slowly loosen the top two bolts. Allow the water to drain from the bottom of the pump. When the water has finished draining, remove the two top bolts. Remove the motor straight out from the volute being careful of its attached impeller. The motor is heavy, do not drop it!
7. Locate the snap bushing in the centre of the back of the motor housing and pry it out with a screwdriver. Insert a straight-blade screwdriver into the snap bushing hole and into the slot in the end of the motor shaft to lock the rotor.
8. While holding the rotor (step 7), unscrew the plastic impeller off the motor shaft by hand turning it clockwise (i.e. opposite to most bolts and nuts!). Place the motor on its back, with its shaft up.
9. Remove the rotary part of the mechanical seal by gently pulling it off the shaft. If too tight use two small flat bladed screwdrivers. Gently pry it off the shaft by placing the flat side of the blades onto opposite sides of the mechanical seal.
10. Remove the stationary part of the seal by gently prying it off the steel faceplate.
11. Remove any corrosion present on the stainless steel motor shaft with a non-metallic brush or scrub pad. Do not use a wire brush or steel wool.
12. Install the new stationary part of the seal into the faceplate: first, the rubber cup by firmly pressing it down until it bottoms, then the ceramic disk. The disk face with a circular groove should be put against the rubber cup (the visible disk face should be smooth). Press the disk firmly down until it too bottoms into the rubber cup. The ceramic disk should be clean. If needed, wipe it with alcohol and a soft cloth.
13. Install the new rotating part of the seal by gently pushing it, by hand, onto the shaft (graphite ring first) until its steel cap stops on the shaft.

Check that:

- a) The height of the steel cap over the ceramic disk is between 0.33" and 0.35" (8.4 mm and 8.9 mm). If it is more than 0.35" (8.9 mm), then try pushing it further down, carefully, but harder.
- b) The graphite disk is pressed against the ceramic disk (by a spring inside of it).

***If either (a) or (b) is not happening, then contact Armstrong Technical Support:
phone (416) 755-2291 or e-mail techsupport@armlink.com.***

14. "Lock" again the motor rotor and shaft as per step 7 above, in order to perform the next step.
15. Fasten the plastic impeller onto the shaft, turning it by hand counter-clockwise until it stops (when it touches the seal's steel cap). Do not tighten it excessively.
16. Ensure the gasket is properly seated in the pump casing (volute) gasket groove. Holding the motor body, insert the impeller straight into the volute. Verify the gasket was not dislodged during insertion, and is still seated properly. Hold the motor body steady while fastening the four bolts that attach the motor to the pump casing (volute). Tighten evenly and diagonally. There should be a small, even gap of about 0.02" (0.5 mm) all around between the motor flange and the pump casing (volute).
17. Follow the START UP instructions and check for leaks.

REPLACEMENT PARTS LIST For ARMflo E Series Circulators

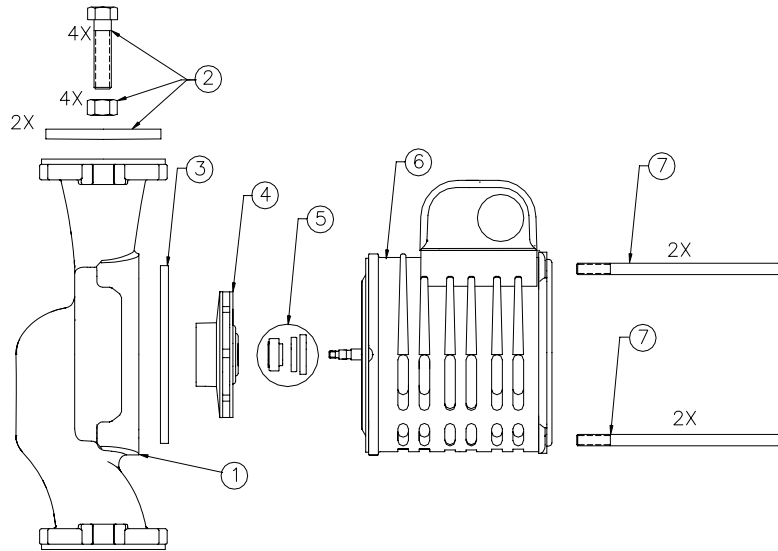

Item No.	Part Description	E7	E8	E9	E10	E11	E12	E13
1	Body - Cast Iron		880200-111		880200-011		880210-111	880200-011
	Body - Bronze		880200-141		880200-041		880210-141	880200-041
2	Flange Hardware Kit		810120-244		810120-204		810120-244	810120-204
3	Body Gasket		880200-071				880210-071	880200-071
4	Impeller	880200-033	880200-031	880200-030	880200-029	880200-028	880210-035	880200-034
5	Mechanical Seal		880200-277					
6	Motor Assembly - 120 V	880200-282		880200-082			880210-082	880200-082
	Motor Assembly - 240 V	--		880200-182			--	880200-182
7	Motor Housing Cap Screw		911117-236					

Item No.	Part Description	E14	E16	E30	E32	E33
1	Body - Cast Iron	880210-111	880200-211	880210-011		
	Body - Bronze	880210-141	880200-241	80210-041		
2	Flange Hardware Kit	810120-244	810120-212			
3	Body Gasket	880210-071	880200-071			
4	Impeller	880210-034	880200-032	880210-036	880210-130	880210-033
5	Mechanical Seal		880200-277			
6	Motor Assembly - 120 V	880210-082	880200-082	880210-182		
	Motor Assembly - 240 V	--	880200-182	--		
7	Motor Housing Cap Screw		911117-236			

S. A. Armstrong Limited
23 Bertrand Avenue
Toronto, Ontario
Canada, M1L 2P3
T: (416) 755-2291
F (Main): (416) 759-9101

Armstrong Pumps Inc.
93 East Avenue
North Tonawanda, New York
U.S.A. 14120-6594
T: (716) 693-8813
F: (716) 693-8970

Armstrong Holden Brooke Pullen
Wenlock Way
Manchester
United Kingdom, M12 5JL
T: +44 (0) 1612 232223
F: +44 (0) 1612 209660

