

MODEL DB - BELT DRIVE CENTRIFUGAL ROOF EXHAUSTER

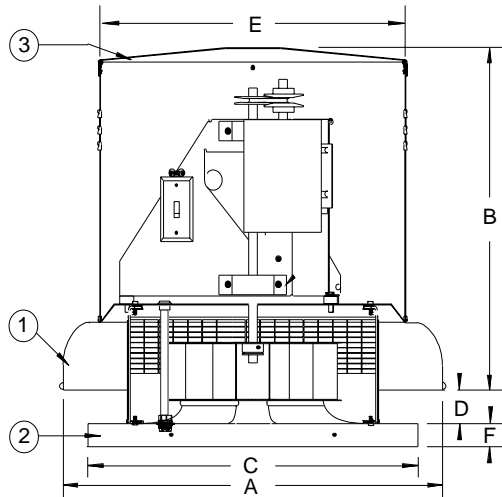

OPTIONAL

STANDARD CONSTRUCTION FEATURES

- All aluminum exterior construction.
- Stainless steel exterior fasteners.
- Ventilated motor compartment.
- Pre-punched curb cap with welded corners.
- Aluminum non-overloading wheel.
- Adjustable V-Belt drive.
- Motor & drives factory mounted (except 184T and larger).
- Mounted service disconnect (except 2 spd and XP motors).
- Pillow block ball bearings (L50 = 200K) with lube fittings.
- Internal wiring chase.
- Aluminum birdscreen and windband.
- Neoprene vibration isolators.
- AMCA Certified Sound and Air performance.

FAN SIZE	DIMENSIONS (Inches)								Dampener OD	MIN. METAL THICKNESS (ALUM)			MAX WT.
	A	B	C	D	E	F	G	H		SKIRT ①	CURB CAP ②	LID COVER ③	
6-8-9	20 1/2	17 1/2	16 1/2	3 1/2	16 1/8	1 3/4	15	12	11	.063	.050	.050	43
11	28 3/8	23	24	3	22 1/2	2	22 1/2	19 1/2	18				70
12	28 3/8	23	24	3 3/4	22 1/2	2	22 1/2	19 1/2	18				70
14	28 3/8	23	24	3 1/4	22 1/2	2	22 1/2	19 1/2	18	.080	.080	.050	70
16	32 1/4	23 3/4	24	5 3/4	26 1/4	2 1/2	22 1/2	19 1/2	18				79
18	32 1/4	24	29 1/2	4 1/2	26 1/4	2 1/2	28	24 3/4	24	.090	.080	.050	96
20	36 3/4	24 1/2	29 1/2	4	26 1/4	2 1/2	28	24 3/4	24				98
24	41 1/4	26 1/2	35 3/4	8	30	2	34	30 3/4	30	.100	.090	.050	155
30	58 3/8	37	42 1/2	5 1/2	41	2 1/2	41	37 3/4	36				265
36	58 3/8	37	42 1/2	10	41	2 1/2	41	37 3/4	36	.100	.090	.050	275
42	73	40 1/4	55	10	54 5/8	2 1/2	53 1/2	50 1/4	48				425
48	73	40 1/4	55	13	54 5/8	2 1/2	53 1/2	50 1/4	48				550

- A. Skirt OD (Dia). E. Motor Cover OD (Dia).
 B. Height. F. Curb Cap Flange.
 C. Curb Cap OD. G. Recommended Roof Curb OD (allows 3/4" for flashing).
 D. Skirt Height. H. Recommended Roof Opening.

DIMENSIONS REPRESENT GENERAL CONSTRUCTION AND MAY VARY SLIGHTLY. CONTACT FACTORY FOR CERTIFIED DRAWINGS.

FAN SPECIFICATIONS									MOTOR SPECIFICATIONS				
Line	Quan.	Model No.	Tag	C F M	SP	Fan RPM	BHP	Sones	HP	Volts	Phase	Hertz	Encl
1													
2													
3													
4													
5													

ACCESSORY ITEMS	1	2	3	4	5	ACCESSORY ITEMS	1	2	3	4	5
<input type="checkbox"/>						<input type="checkbox"/>					
<input type="checkbox"/>						<input type="checkbox"/>					
<input type="checkbox"/>						<input type="checkbox"/>					
<input type="checkbox"/>						<input type="checkbox"/>					
<input type="checkbox"/>						<input type="checkbox"/>					