

MODEL KSF KITCHEN SUPPLY FAN - Submittal Data

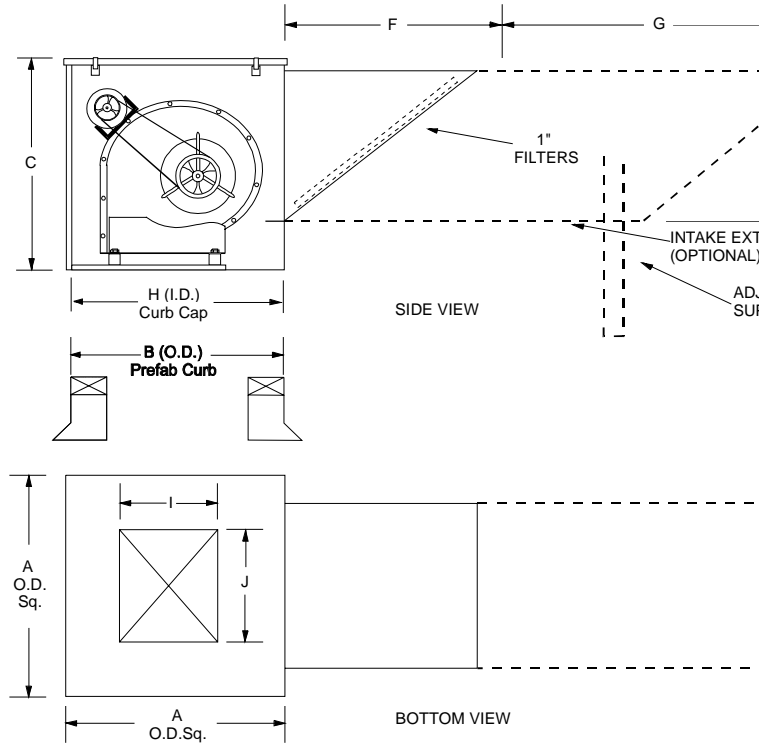

SIZE	A	B	C	D	E	F	G	H Sq	Damper O.D.	I	J	FILTERS (QTY)
9	24 1/2	22 1/2	23	18	18	17 3/4	78	24 1/2	19"	10 1/2	12	17 1/2 X 23 (1)
10	28 1/4	26 1/2	30	21 3/4	22	21 3/4	70	28 1/4	23"	11 5/8	13 1/4	21 1/2 X 28 1/2 (1)
12	32 1/2	31	33	27 1/4	28 3/8	27 1/4	51 1/4	32 1/2	27"	13 5/8	15 7/8	25 1/2 X 35 1/2 (1)
15	32 1/2	31	37	28 3/4	31 1/2	37	56	32 1/2	27"	16 1/4	18 7/8	21 1/2 X 28 1/2 (2)
18	36 1/2	35	41	31	36 1/2	36	48	36 1/2	30"	19	22 1/4	24 X 30 (2)
20	51	49 1/2	49	46 1/8	37 1/2	37 1/2	31	51	45"	23	25	25 1/2 X 45 1/2 (2)

FAN SPECIFICATIONS									MOTOR SPECIFICATIONS				
Line	Quan.	Model No.	Tag	CFM	Static	Fan RPM	BHP	Sones	HP	Volts	Phase	Hertz	Encl
1													
2													
3													
4													
5													

ACCESSORY ITEMS	1	2	3	4	5	ACCESSORY ITEM	1	2	3	4	5
<input type="checkbox"/>						<input type="checkbox"/>					
<input type="checkbox"/>						<input type="checkbox"/>					
<input type="checkbox"/>						<input type="checkbox"/>					
<input type="checkbox"/>						<input type="checkbox"/>					
<input type="checkbox"/>						<input type="checkbox"/>					

Project: _____ Submitted: _____
 Customer: _____ Approved: _____
 Location: _____